

This article was downloaded by:

On: 24 January 2011

Access details: *Access Details: Free Access*

Publisher *Taylor & Francis*

Informa Ltd Registered in England and Wales Registered Number: 1072954 Registered office: Mortimer House, 37-41 Mortimer Street, London W1T 3JH, UK



Journal of Macromolecular Science, Part A

Publication details, including instructions for authors and subscription information:

<http://www.informaworld.com/smpp/title~content=t713597274>

Grafting of 2-Ethylhexyl Acrylate with Urea on to Gelatin Film by Gamma Radiation

Farhana Gul-E-Noor^a; Mubarak A. Khan^b; Sushanta Ghoshal^a; Russel A. Mazid^b; A.M. Sarwaruddin Chowdhury^a; Ruhul A. Khan^b

^a Department of Applied Chemistry and Chemical Technology, University of Dhaka, Dhaka, Bangladesh ^b Radiation and Polymer Chemistry Laboratory, Institute of Nuclear Science and Technology, Bangladesh Atomic Energy Commission, Dhaka, Bangladesh

To cite this Article Gul-E-Noor, Farhana , Khan, Mubarak A. , Ghoshal, Sushanta , Mazid, Russel A. , Sarwaruddin Chowdhury, A.M. and Khan, Ruhul A.(2009) 'Grafting of 2-Ethylhexyl Acrylate with Urea on to Gelatin Film by Gamma Radiation', *Journal of Macromolecular Science, Part A*, 46: 6, 615 – 624

To link to this Article: DOI: 10.1080/10601320902851926

URL: <http://dx.doi.org/10.1080/10601320902851926>

PLEASE SCROLL DOWN FOR ARTICLE

Full terms and conditions of use: <http://www.informaworld.com/terms-and-conditions-of-access.pdf>

This article may be used for research, teaching and private study purposes. Any substantial or systematic reproduction, re-distribution, re-selling, loan or sub-licensing, systematic supply or distribution in any form to anyone is expressly forbidden.

The publisher does not give any warranty express or implied or make any representation that the contents will be complete or accurate or up to date. The accuracy of any instructions, formulae and drug doses should be independently verified with primary sources. The publisher shall not be liable for any loss, actions, claims, proceedings, demand or costs or damages whatsoever or howsoever caused arising directly or indirectly in connection with or arising out of the use of this material.

Grafting of 2-Ethylhexyl Acrylate with Urea on to Gelatin Film by Gamma Radiation

FARHANA GUL-E-NOOR¹, MUBARAK A. KHAN^{2,*}, SUSHANTA GHOSHAL¹, RUSSEL A. MAZID²,
A. M. SARWARUDDIN CHOWDHURY¹ and RUHUL A. KHAN²

¹Department of Applied Chemistry and Chemical Technology, University of Dhaka, Dhaka 1000, Bangladesh

²Radiation and Polymer Chemistry Laboratory, Institute of Nuclear Science and Technology, Bangladesh Atomic Energy Commission, P.O. Box 3787, Dhaka 1000, Bangladesh

Received November 2008, Accepted January 2009

Gelatin films were prepared by dissolving gelatin granules in hot distilled water (90°C) followed by casting. Tensile strength (TS), tensile modulus (TM) and elongation at break (Eb %) of the films were found to be 27.0 MPa, 100 MPa and 4%, respectively. Gelatin films were irradiated under Co-60 source at different doses (50–1000 krad) and it was found that TS and TM of the films increased up to 48% and 120%, respectively at 250 krad dose. Urea (1–5 wt%) was added to the gelatin solution and films were prepared by casting, then irradiated and found that TS of the 2% urea containing gelatin film was 44.3 MPa which is about 64% enhancement of TS compared to raw gelatin films at 100 krad. Gelatin-urea films were then soaked in 1–10 wt% of EHA (2-Ethylhexyl acrylate) solutions at varying soaking time and irradiated under gamma radiation up to 500 krad. The highest TS and Eb were found to be 57 MPa and 11%, respectively for the 3% EHA and 3 min soaking time at 100 krad radiation dose.

Keywords: Gelatin, thin films, gamma radiation, urea, 2-ethylhexyl acrylate

1 Introduction

Gelatin is a structural protein. According to the National Formulary of USA (1), gelatin is defined as a product obtained by the partial hydrolysis of collagen derived from skin, white connective tissue and bones of animals. Gelatin normally contains about 15% water, 1–4% inorganic salts and trace amount of grease. The properties of gelatin depend on the major protein constituent derived from the breakdown of collagen. Elemental percentages of gelatin (2) are as follows: Carbon 50.5%, Hydrogen 6.8%, Nitrogen 17% and Oxygen 25.2%. The structure of gelatin (3) is given in Scheme 1.

Gelatin possesses priority for various applications in medical sciences. Gelatin, a natural polymer is used as a tissue engineering scaffold. Gelatin based sponges composed of gelatin and polysaccharides have the potential for wound dressing materials. Crosslinked gelatin sponges have also been investigated for their application as a component of artificial skin or tissue transplants to promote epithelialization and granulation tissue formation in wound (3).

It degrades very quickly to the environment and this property creates some advantages and disadvantages for its applications. The number of bi and poly functional organic and inorganic compounds can interact with the particular gelatin functions, which enhance the possibilities of modifying the properties (4). Graft copolymerization (5,6) is used to improve the properties of gelatin. Researchers have reported the successful graft polymerization on gelatin and subsequent change in the thermal and structural properties of gelatin. (7). The interrelated effects of gelatin modification, content, surface hydrophilicity, tensile properties, swelling/degradation and drug-release kinetics of a novel interpenetrating network system containing gelatin and poly(ethylene glycol) diacrylate are evaluated (8). The swelling rate and the equilibrium swelling of gelatin by casting are also studied (9). Compression-molded gelatin/starch (1:1 w/w) blend shows improved mechanical properties as compared to gelatin (10). Gelatin graft copolymer macromolecules are formed when methyl methacrylate is polymerized in aqueous medium in the presence of gelatin (11) Research has been previously done to explore the irradiation effects on gelatin. It is reported that, gamma radiation increased the crosslinking between protein chains which increase the mechanical properties of the film (12). Cheorun et al. (13) observed that gamma radiation enhance the tensile properties (TS and Eb) of the pectin and gelatin based films. Gamma radiation

*Address correspondence to: Mubarak A. Khan, Radiation and Polymer Chemistry Laboratory, Institute of Nuclear Science and Technology, Bangladesh Atomic Energy Commission, P.O. Box 3787, Dhaka 1000, Bangladesh. E-mail: makhan.inst@gmail.com

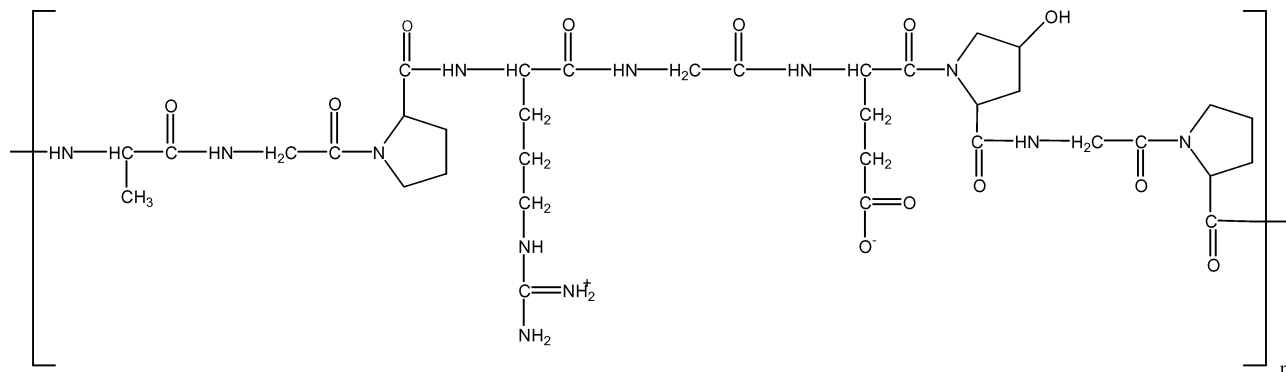

Sch. 1. Structure of gelatin.

decontaminates the edible gelatin (14) and is also capable of increasing the digestible energy of agricultural by-products (15). A great deal of work has also been carried out on the gelatin renaturation (16,17), and it may be mentioned that gelatin is a denatured product of collagen. Denaturation is a structural change in a protein that results in a loss of its biological properties (18). Due to denaturation, protein lost its characteristic properties such as solubility in solvent, enzymatic activity etc. It also affects the functional property of protein (19). Physical modification of gelatin includes renaturation of the collagen-like helical structure and orientation of gelatin macromolecules (4). Renaturation is the conversion of denatured protein to its native configuration (20). In the present work, urea is used as an additive to increase the property of the finished product and accelerating the grafting condition. The role of EHA is to grafting onto gelatin films for the enhancement of the properties of thin films of gelatin.

The present work was undertaken to prepare gelatin films and to study the effect of gamma radiation on the tensile properties. The ultimate goal of this research work was to monitor the mechanical properties of gelatin films by adding urea and then soaked in EHA (monomer) followed by gamma radiation.

2 Experimental

2.1 Materials

Gelatin (Bloom Strength-185) (pharmaceutical grade) was collected from the Opsonin Pharma Limited, Barishal, Bangladesh. The monofunctional monomer, 2-Ethylhexyl acrylate (EHA) was purchased from Fluka, Switzerland. Urea was collected from BDH, UK. Methanol was used and obtained from Merck, Germany.

2.2 Methods

Granules of gelatin (8 gm) were dissolved in 200 ml of distilled water and heated for 2 h at 90°C at normal pressure.

The gelatin solution was cast on to release film (silicon cloth) covered frame mounted on flat glass plate for film formation and then dried in an oven for 8 h at 70°C. The dried films (about 0.30 mm thickness) thus prepared were peeled off and cut into small pieces (50 × 10 mm²) using conventional scissors. The films were irradiated under gamma radiation (Co-60) with different intensities from 50 to 1000 krad at a dose rate of 300 krad/hour. Mechanical properties of the films were investigated by the Universal Testing Machine (Hounsfield Series S, UK). The load range was 500 N with 10 mm/min crosshead speed and 20 mm gauge length. For the preparation of gelatin urea films, 1–5 wt% of urea (Table 1) was dissolved in hot water and mixed in the gelatin solution, then the films were prepared using the casting mentioned above. EHA solutions were prepared in methanol. Gelatin films were soaked at different soaking times (1–7 min). After soaking, the films were irradiated from 50 to 500 krad.

3 Results and Discussion

Data presented here are average values of at least five samples and the associated error is ±1%.

3.1 Effect of Gamma Radiation on Pure Gelatin Film

Pure gelatin films were irradiated under a Co-60 source to study the effect of radiation on the mechanical properties such as tensile strength (TS), elongation at break (Eb) and

Table 1. Composition (% w/w) of the gelatin films with urea.

Expressed as	Composition	
	Gelatin	Urea
C-0	100	0
C-1	99	1
C-2	98	2
C-3	97	3
C-4	95	5

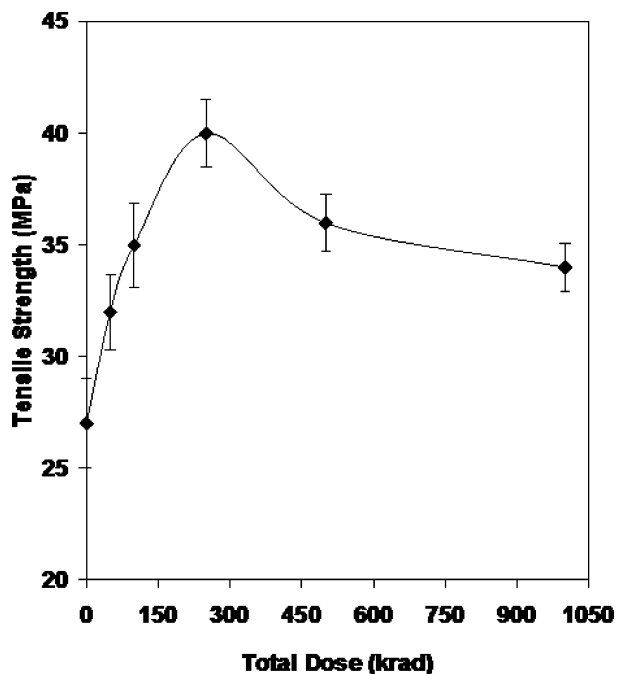

Fig. 1. Tensile strength of pure gelatin films against the total radiation dose.

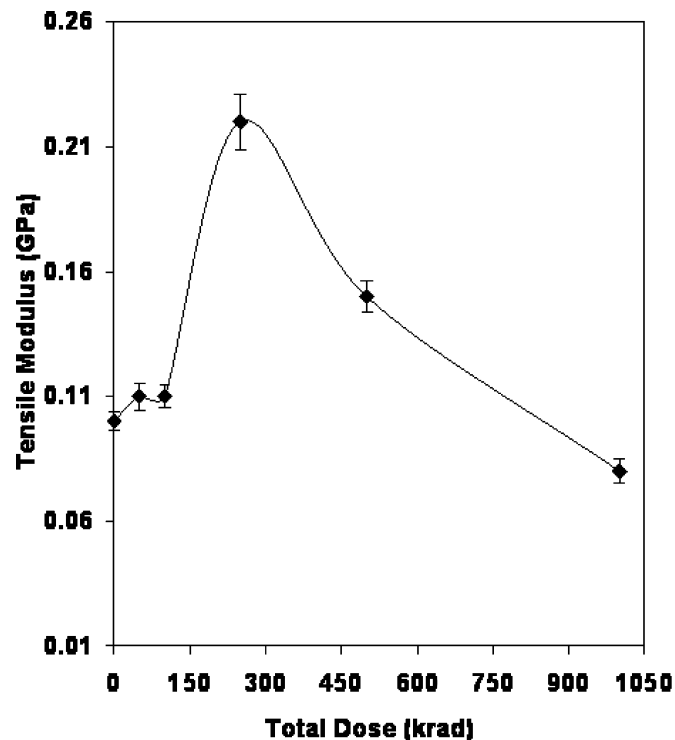

Fig. 2. Tensile modulus of pure gelatin films against the total radiation dose.

tensile modulus (TM) of the gelatin films. Gelatin films were irradiated at different doses (50, 100, 250, 500 and 1000 krad) at a dose rate of 300 krad/hour. The results are given in Figures 1 and 2. The TS and TM of the pure gelatin films are found to be 27 MPa and 0.1 GPa, respectively (expressed as 0 krad in the figures). It is found that with the increase of total dose of gamma radiation, TS values increases gradually. At 50, 100 and 250 krad doses, TS of the irradiated films are 32, 35 and 40 MPa which is about 18, 29 and 48% higher, respectively, compared to the pure gelatin film. After that, an increase of radiation dose decreases the TS values gradually. At 500 and 1000 krad, the TS value goes to 36 and 34 MPa, respectively. These values are still higher than the pure gelatin film but 10 and 15% lower than the films which are irradiated at 250 krad. So, with the exposure of gamma radiation, the TS of pure gelatin film increases. The TM values increase with the increase of gamma radiation and the nature is similar to that of TS and shown in Figure 2. At 50, 250 and 1000 krad of doses, the TM values found 0.11, 0.22 and 0.08 GPa, respectively. With the treatment of 1000 krad of gamma radiation on pure gelatin films attributed almost 20% reduction of modulus compared to the pure gelatin film. On the other hand, elongation properties of irradiated films are found to be almost similar to the pure gelatin films.

Crosslinking and chain scission occurred when polymers are exposed to gamma radiation (21-24). Polysaccharides and other natural polymers generally degrade by breaking the glycosidic linkage under gamma radiation (22). Gelatin is a natural biopolymer which consists of protein molecules

and can easily fragment due to gamma radiation. The nature of probable chain scission of gelatin molecule with the exposure of gamma radiation is given in Scheme 2 where some of the probable free radicals are shown. The generated free radicals may crosslink each other and form more crosslinked sites with the exposure of gamma ray, as a result, mechanical properties might be increased. It is reported in the literature (23,24) that cellulose and chitosan molecules also form free radicals in a similar nature when irradiation by gamma source.

3.2 Effect of Urea on Pure Gelatin Film

Four types gelatin based films were prepared using 1–5 wt% of urea in aqueous gelatin solution and the composition is shown in Table 1. The mechanical properties of the prepared films were evaluated and presented in Figures 3 and 4. Mechanical properties of urea containing gelatin films without radiation is also measured and given in the figures denoted by zero radiation dose.

The results of TS are shown in Figure 3, where the values are tabulated against total radiation dose as a function of different formulations (C-0 to C-4). The TS value of pure gelatin film is denoted as C-0 in the figure. It was noted that with the incorporation of urea into the gelatin films attributed decrease of TS values as indicated in the figure. For pure gelatin films, the TS was found to be 27 MPa, but a decrease in TS was observed for C-3 (22.5 MPa) and

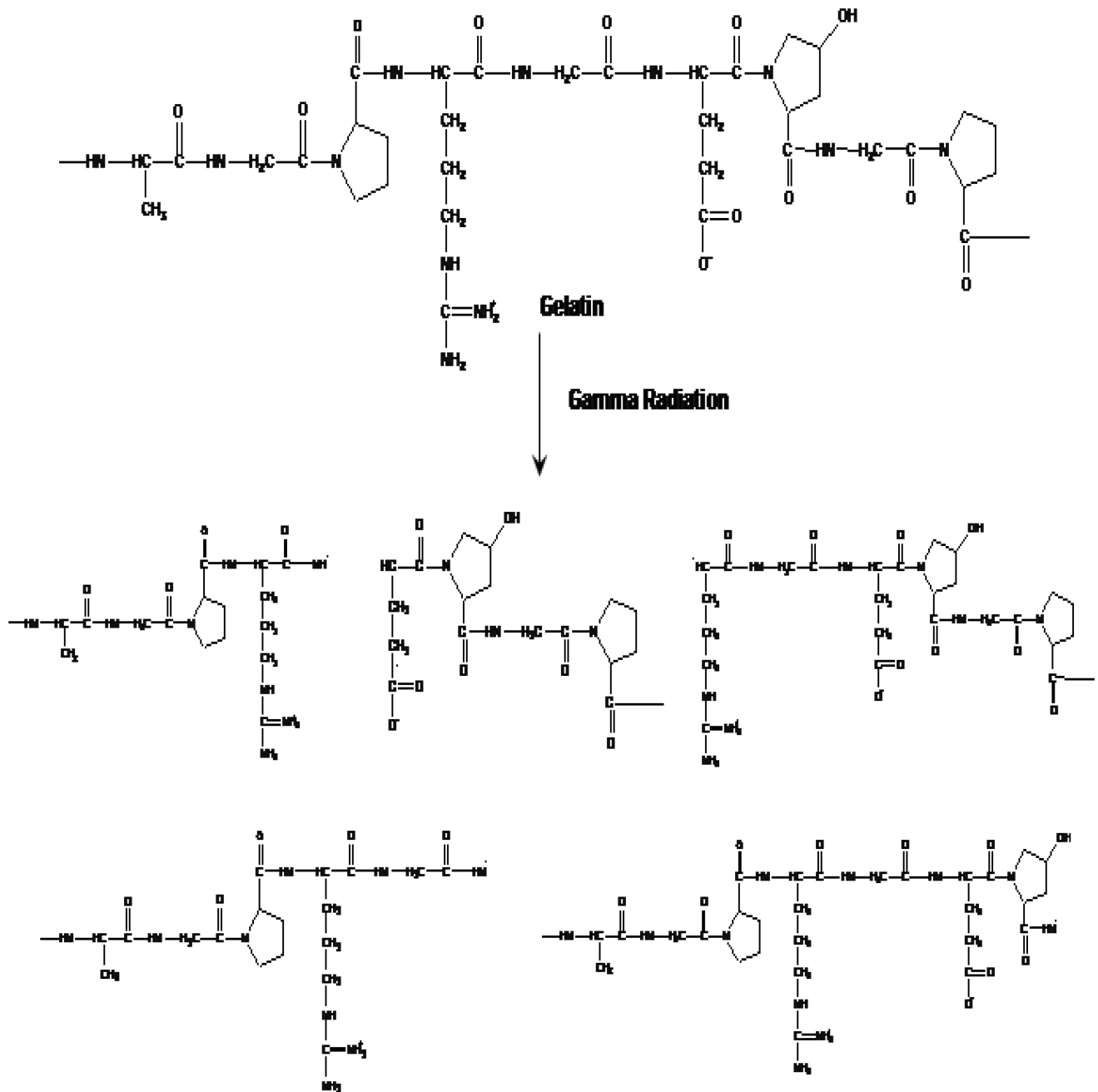

Sch. 2. Probable free radicals generated from gelatin with the exposure of gamma radiation.

C-4 (17.7 MPa). Here, urea is acted as a filler so a decrease in TS was found. Again, for pure gelatin films, TS values increased with the increase of radiation dose and are discussed above. Urea containing gelatin films also showed that TS values increases with the increase of the radiation dose up to 100 krad, then decreases. For non-irradiated urea containing gelatin films, the TS values slightly decreases and are shown in the figure (denoted by 0 krad). The TS values of 1, 2, 3 and 5% urea containing gelatin films are 37.1, 44.3, 38.6 and 34.3 MPa, respectively at 100 krad radiation dose. At 100 krad of gamma dose, it

was found that 2% urea containing films (C-2) showed the highest TS values compared to other types of gelatin films including pure gelatin films. For all compositions at 100 krad dose, TS values increases more than the corresponding pure gelatin films and it was found that the TS value of 2% urea containing films showed almost 64% enhancement compared to the pure gelatin films. Gelatin may react with urea during gamma radiation to a certain dose limit. The reaction mechanism is shown in Scheme 3. Sarkar et al. reported that the hydroxyl (-OH) group of gelatin reacted in a similar mechanism with the polyester urethane (3). On the

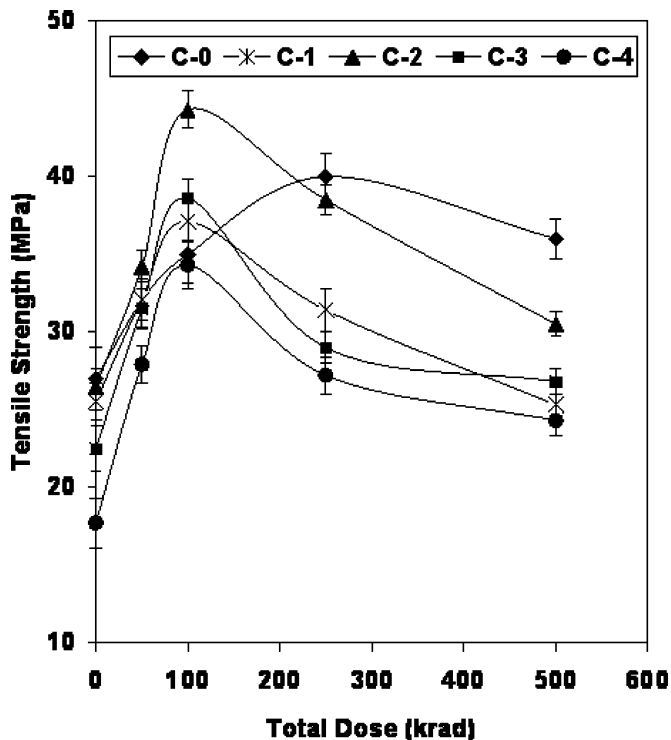
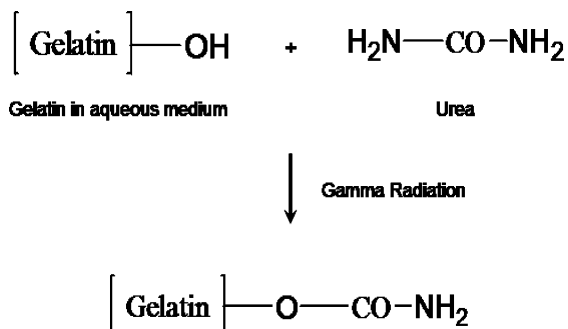

Fig. 3. Tensile strength of gelatin-urea films against the total radiation dose with respect to the percentage of urea.

other hand, Eb values increases (Fig. 4) with the increase of radiation dose up to 100 krad (containing 3% urea) then decreases. The highest Eb value (9.6%) is found for the C-3 formulation at 100 krad radiation dose.

The TS and Eb values of urea containing gelatin films increases with the low dose of gamma radiation, attains the maximum value at 100 krad radiation dose, and then decreases as the radiation dose increases up to 500 krad as shown in Figures 3–4, respectively. This result indicates that, at a particular radiation dose, maximum TS and Eb are achieved and further radiation degrades the films. On the other hand, urea may copolymerize with gelatin because of mixing. At a higher percentage of urea, poly-urea may



Sch. 3. Reaction mechanism between gelatin and urea with the exposure of gamma radiation.

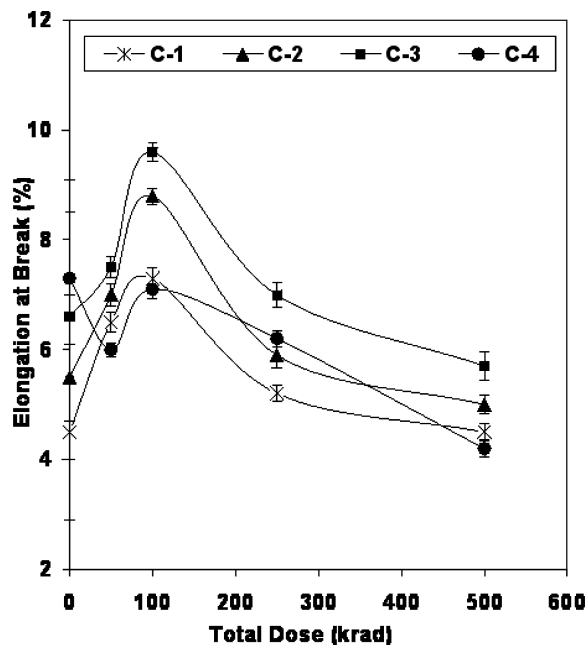

Fig. 4. Elongation at break of gelatin-urea films against the total radiation dose with respect to percentage of urea.

form (25–27), and probably might be responsible for the decrease of TS. Unreacted urea may also be responsible for the increases of the elongation properties (28–29). From the above discussion; it is found that at 250 krad of gamma dose, pure gelatin films performed with the best results. In contrast, urea containing gelatin films showed the best results at 100 krad of gamma dose. This is because of the crosslinking of gelatin with urea at 100 krad dose, but at 250 krad dose, degradation of the films might be responsible for the decrease of the TS values.

The main constituent of gelatin is large and complex polypeptide molecules of the same amino acid composition as the parent collagen (Scheme 1). The specific features of gelatin properties can be determined from structural diversity of gelatin chain units. In this investigation, the addition of urea (1–5%) decreases TS values of pure gelatin films. The reason for the decrease of TS might arise from denaturation properties of urea. It is reported that the addition of urea to the aqueous gelatin solution hinders the renaturation of the gelatin (4). The denaturation of gelatin occurs when it is exposed to heat and or in aqueous medium (30). The terms renaturation and denaturation are already mentioned in the introduction section. Urea denatured protein is also found through favorable interaction with peptide backbone (31). However, in this experiment, gelatin-urea films were prepared using 1–5% urea. As a result, the effect is not as intensive in the case of protein denaturation. But, the addition of urea changed the mechanical properties of gelatin films. Here, urea was used as an additive which lowered the brittleness of the gelatin film. It is also expected that there is no relation between structural changes with

Table 2. Composition (% w/w) of soaking formulations containing EHA monomer.

Formulations Expressed as	Composition	
	EHA	Methanol
F-1	1	99
F-2	3	97
F-3	5	95
F-4	10	90

the increase or decrease of the quantity of urea in gelatin. When these films were irradiated by gamma source, the tensile properties were significantly changed. This may be due to the effect of radiation doses.

3.3 Effect of EHA on Pure Gelatin Film

To find out the effect of EHA on gelatin films, a number of formulations were prepared and are given in Table 2. The tensile properties (TS and Eb) of the EHA grafted and irradiated gelatin films are given in Tables 3 and 4, respectively.

From Table 3 it is observed that raw gelatin films grafted with 3% EHA (F-2 formulation) showed the highest TS (42.2 MPa) at a 100 krad radiation dose which is about 56% enhancement. The proposed reaction mechanism between gelatin and EHA is shown in Scheme 4. Monomer concentration plays the important role. The TS value increases up to the monomer concentration 3%, and then decreases with the increase of monomer concentration. Higher monomer concentration may lead to the homopolymer formation causing the decrease of TS. The Eb value increases about

Table 3. Tensile strength (TS) of gelatin film grafted with EHA formulations (F-1, F-2, F-3 and F-4) against radiation dose.

Radiation Dose (krad)	Tensile Strength (MPa) \pm Standard Deviation			
	F1	F2	F3	F4
50	35.3 \pm 1.0	38.9 \pm 1.7	36.2 \pm 1.3	34.0 \pm 1.2
100	38.6 \pm 1.6	42.2 \pm 1.9	39.9 \pm 1.5	36.8 \pm 1.6
250	36.5 \pm 1.2	38.8 \pm 1.5	34.2 \pm 0.9	31.5 \pm 1.3
500	30.9 \pm 0.8	35.4 \pm 1.2	32.0 \pm 1.0	28.1 \pm 0.6

Table 4. Elongation at break (Eb) of gelatin film grafted with EHA formulations (F-1, F-2, F-3 and F-4) against radiation dose.

Radiation Dose (krad)	Elongation at break (%) \pm Standard Deviation			
	F1	F2	F3	F4
50	3.6 \pm 0.12	4.8 \pm 0.13	6.1 \pm 0.19	6.7 \pm 0.25
100	4.0 \pm 0.2	5.2 \pm 0.19	6.8 \pm 0.28	7.7 \pm 0.36
250	3.9 \pm 0.14	5.2 \pm 0.16	6.1 \pm 0.21	7.1 \pm 0.28
500	3.3 \pm 0.1	4.6 \pm 0.12	5.3 \pm 0.11	6.8 \pm 0.17

92% at 100 krad radiation dose (F4 formulation) and then decreased as shown in Table 4. At the higher radiation dose, TS and Eb values decreased due to the radiation degradation of the gelatin films (28). The raw gelatin films perform with better tensile properties after soaking in the monomer formulations.

3.4 Optimization of Soaking Time

Gelatin films containing 2% urea (C-2) showed better mechanical properties when soaked in a F-2 formulation for

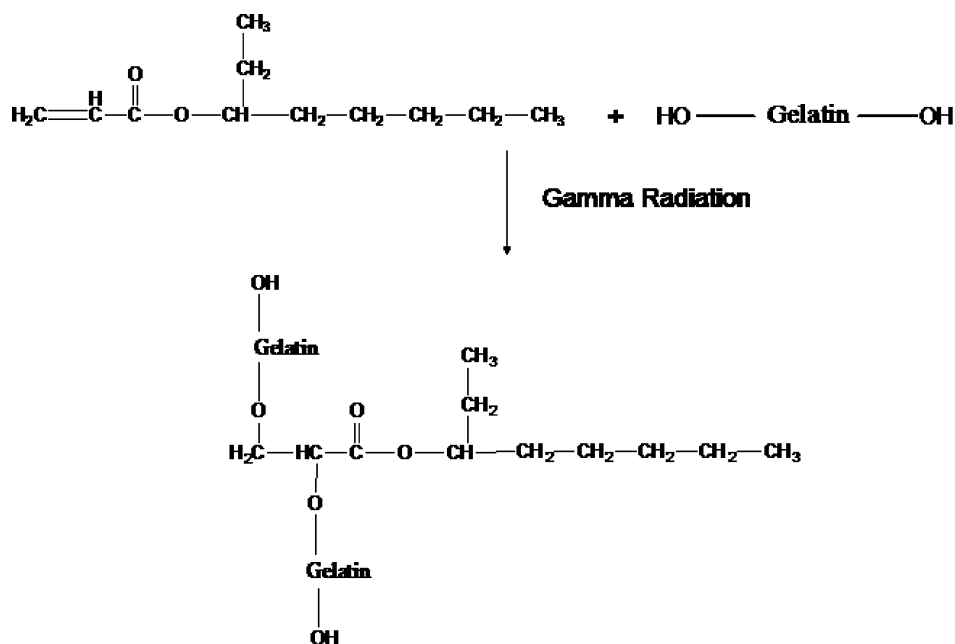
**Sch. 4.** Probable reaction mechanism between EHA and gelatin with the exposure of gamma radiation.

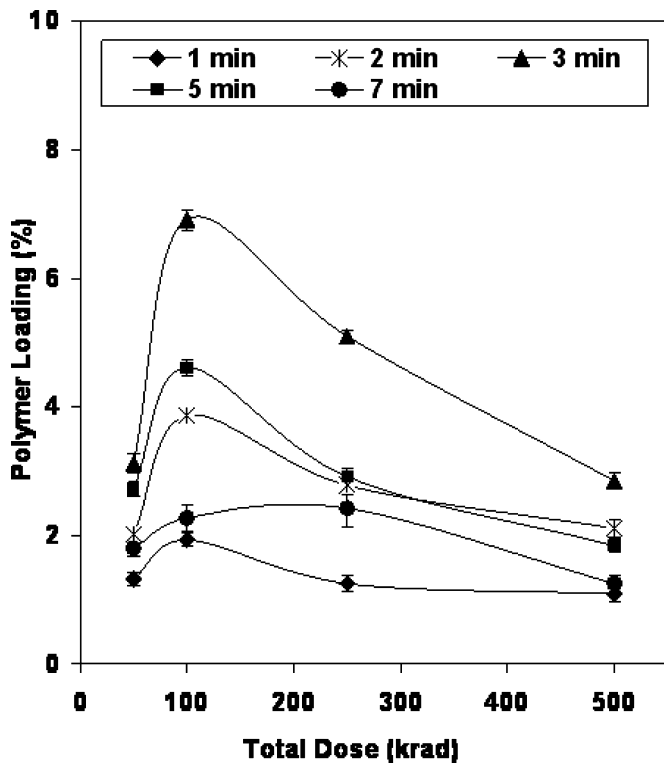

Fig. 5. Polymer loading of 2% urea incorporated gelatin films against the total radiation dose with respect to soaking time for F2 monomer formulation.

3 min, so, these films were chosen to optimize soaking time (1, 2, 3, 5 and 7 min). After soaking, the films were irradiated at 50, 100, 250 and 500 krad radiation dose and characterized. In Figure 5, the polymer loading values are plotted against the total dose with respect to various soaking times. It is found that PL value increases with the increase of soaking time and radiation dose up to 100 krad and then decreases. The highest PL value is 6.9% and is obtained at 3 min soaking time and 100 krad radiation dose. Due to the immersion of gelatin films in methanol and EHA solution, the volume of the gelatin films increased because of diffusion of methanol inside gelatin film. Therefore, increasing the soaking time increases the diffusion of monomer in the film (29, 32,33). The films became twisted and shrank at a higher soaking time.

The TS values are plotted in Figure 6 against the total radiation dose as a function of soaking time. The TS values increase with the increase in soaking time and radiation dose. The highest TS value 57 MPa is found at 100 krad radiation dose at 3 min soaking time. When the soaking time increased, higher swelling leads to an increased diffusion of the monomer into the reaction sites. As a result, the TS value increased. After 3 min soaking time, TS value decreased up to 7 min soaking time. Since gelatin is a heterogeneous mixture of water-soluble proteins of high average molecular mass (34), immersion of gelatin films in methanol for 5 or 7 min time may cause proteins

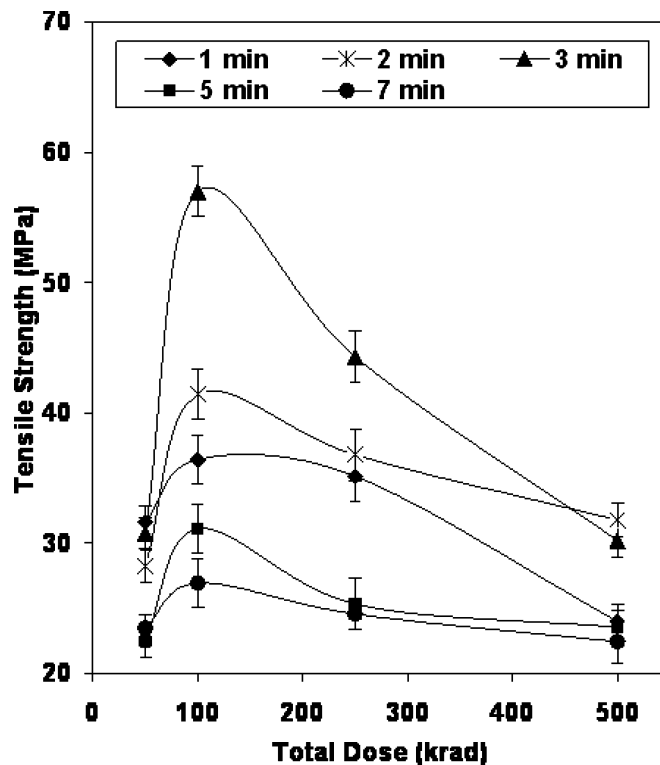

Fig. 6. Tensile strength of 2% urea incorporated gelatin films against the total radiation dose with respect to soaking time for F2 monomer formulation.

intra debonding and was attributed to a decrease in TS. The results of elongation at break (E_b) are presented in Figure 7, where the E_b is plotted against the total radiation dose as a function of soaking time for the F-2 formulation. It is observed that E_b values increase with the increase of soaking time and achieved maximum value 11% for 3 min soaking time and then decreased with the further increase in soaking times. From the above discussion, it is clear that the optimization is achieved for the C-2 composition at soaking formulation F-2 for 3 min soaking time.

3.5 Optimization of EHA Formulations

The films prepared using formulation C-2 was soaked in different formulations of EHA (F-1 to F-4) for 3 min soaking time to optimize a certain formulation. After soaking, the films were irradiated under gamma radiation at different radiation doses (50, 100, 250 and 500 krad) and the mechanical properties were studied.

The polymer loading (PL) of the films at different soaking formulations is determined on the basis of weight gained by the film after soaking the films in EHA solution. The PL values of the treated films are plotted in Figure 8 against total gamma radiation dose with respect to formulations (F-1, F-2, F-3 and F-4) for 2% urea containing

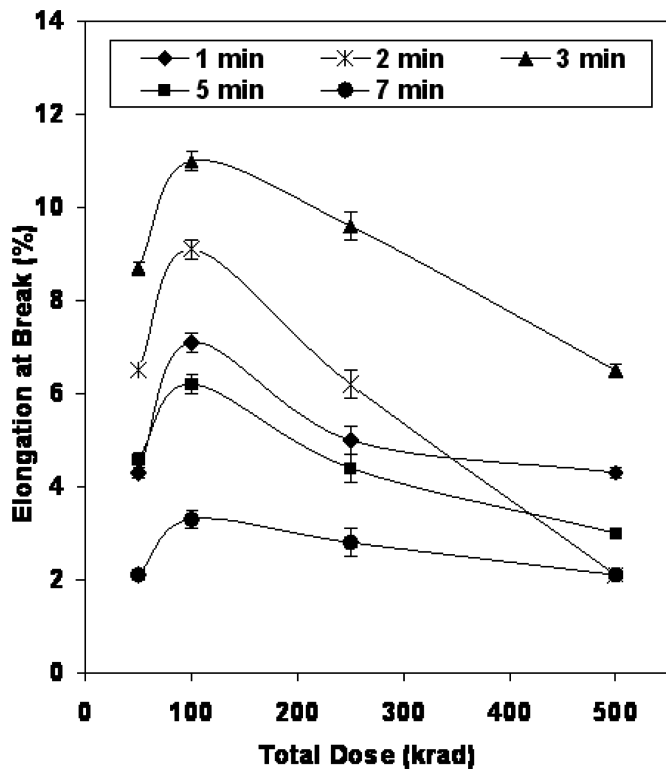

Fig. 7. Elongation at break of 2% urea incorporated gelatin films against the total radiation dose with respect to soaking time for F2 monomer formulation.

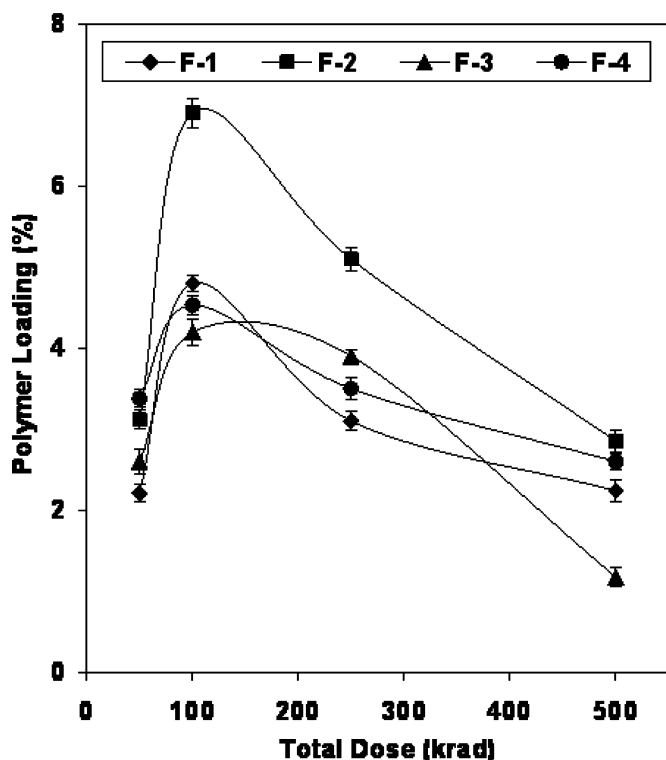

Fig. 8. Polymer loading of 2% urea incorporated gelatin films against the total radiation dose with respect to monomer formulation for 3 min soaking time.

gelatin film at 3 min soaking time. From the figure, it is observed that PL value increases with EHA concentrations up to 3% (F-2) but after that, 5% and 10% showed lower values compared to those of 1% and 3%. At 500 krad, 5% EHA (F-3) performed the lowest PL values. The PL values of 1, 3, 5, and 10% EHA concentrations are 4.8, 6.9, 4.2 and 4.5 respectively at 100 krad radiation dose. The highest PL value found 6.9% at 100 krad (total dose) of gelatin/urea film (C-2).

The results of TS values of the grafted films are plotted in Figure 9 against total radiation dose (50, 100, 250 and 500 krad) with respect to formulations (F-1, F-2, F-3 and F-4) for 2% urea containing gelatin film at 3 min soaking time. It is observed that TS value also increase with EHA concentrations up to 3% and then it decreases with increasing concentration of EHA. The TS values for F-1, F-2, F-3 and F-4 formulations are 44.7, 57, 45.9 and 40.6 MPa, respectively at 100 krad radiation dose. The highest TS value found 57 MPa (100 krad dose) which is about a 111% improvement than that of pure gelatin films. The TS value also increases with the increase of radiation doses and in most of the cases TS value attains maximum at 100 krad (total dose) and then TS value decreases with increasing radiation doses. A higher gamma radiation dose may cause degradation of the polymer and the film becomes brittle.

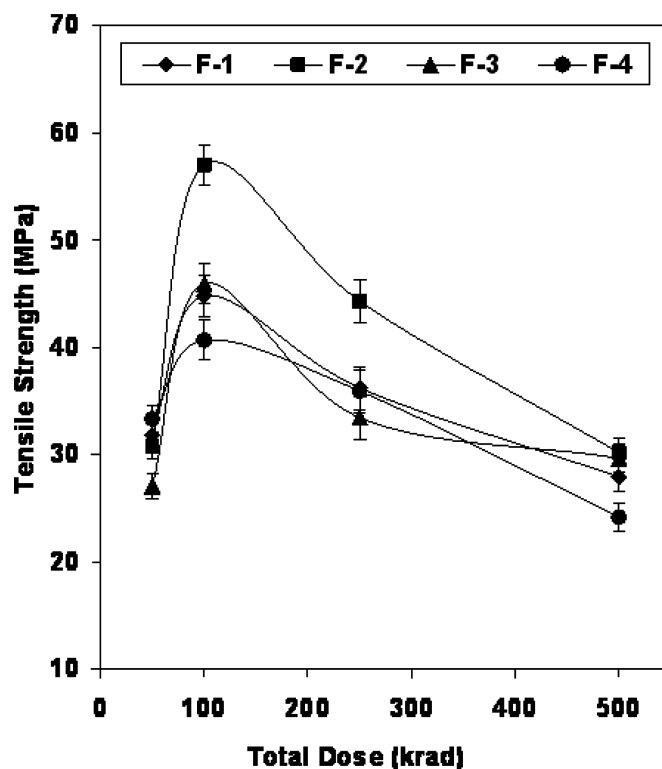

Fig. 9. Tensile strength of 2% urea incorporated gelatin films against the total radiation dose with respect to monomer formulation for 3 min soaking time.

4 Conclusions

It can be concluded that using gamma radiation is one of the potential methods to improve the tensile properties of gelatin films. Minor amounts (1-5%) of urea in gelatin films also have some contribution in developing the properties of gelatin which is indicated in the reaction between gelatin and urea. A significant improvement of the gelatin films were also found when the acrylate group (from EHA) was introduced into the gelatin molecule. So, it is found that using urea and EHA onto gelatin, followed by gamma radiation, decreases the brittleness of gelatin and improves the TS.

References

- National Formulary XVI, United States Pharmacopeial Convention, Inc.; Rockville, Maryland, 1563-1564, 1985.
- Eastone, J.E. Treatise on Collagen. Ramachandran, G.N, Ed. Academic Press: New York, 1-72, 1967.
- Sarkar, S., Chourasia, A., Maji, S., Sadhukhan, S., Kumar, S. and Adhikari, B. (2006) *Indian Academy of Sciences*, 29, 475-484.
- Kozlov, P.V. and Burdygina, G.I. (1983) *Album. Polym.*, 24, 651-666.
- Kaur, I., Misra, B.N., Gupta, A. and Chauhan, G.S. (1998) *Polym. Int.*, 46, 275-279.
- Sivakumar, M., Rajalingam, P., Radhakrishnan, G. and Kothandaraman, H. (1991) *J. Appl. Polym. Sci.*, 43, 1789-1794.
- Dai, C., Chen, Y. and Liu, M. (2006) *J. Appl. Polym. Sci.*, 99(4), 1795-1801.
- Burmania, J.A., Martinez-Diaz, G.J. and Kao, W.J. (2003) *J. Biomed. Mater. Res. Part A*, 67A(1), 224-234.
- Ofner III, C.M. and Schott, H. (1986) *J. Pharm. Sci.*, 75(8), 790-796.
- Apostolov, A.A., Fakirov, S., Evstatiev, M., Hoffmann, J. and Friedrich, K. (2002) *Macromol. Mater. Eng.*, 287(10), 693-697.
- Stejskal, J., Strakova, D. and Kratochvil, P. (1988) *J. Appl. Polym. Sci.*, 36(1), 215-227.
- Ressouany, M., Vachon, C. and Lacroix, M. (1998) *J. Agric. Food Chem.*, 46(4), 1618-1623.
- Jo, C., Kang, H., Lee, N.Y., Kwon, J.H. and Byun, M.W. (2005) *Radiat. Phys. Chem.*, 72, 745-750.
- Fu, J., Shen, W., Bao, J. and Chen, Q. (2000) *Radiat. Phys. Chem.*, 57, 345-348.
- Al-Masri, M. R. and Guenther, K.D. (1999) *Radiat. Phys. Chem.*, 55, 323-329.
- Achet, D. and He, X.W. (1995) *Polymer*, 36(4), 787-791.
- Busnel, J.P., Morris, E.R. and Ross-Murphy, S.B. (1989) *Int. J. Biol. Macromol.*, 11(2), 119-125.
- www.patana.ac.th/linklearn/Linklearn_interface/results/ll.check.asp
- Boye, J.I., Ma, C.-Y. and Harwalkar, V.R. Food Proteins and Their Applications; CRC Press: Ottawa, Ontario, 1997.
- http://www.encyclo.co.uk/define/renaturation
- Peppas, N.A. Hydrogels in Medicine and Pharmacy; CRC Press: Boca Raton, 1, 1, 1987.
- Song, C.L., Yoshii, F., Kume, T. J. (2001) *Macromol. Sci., Pure and Applied Chemistry Part A*, 38(9), 961-971.
- Khan, F., Ahmad, S.R. (1997) *J. Appl. Polym. Sci.*, 65(3), 459-468.
- Hsu, S.C., Don, T.M., Chiu, W.Y. (2002) *J. Appl. Polym. Sci.*, 86(12), 3047-3056.
- Banihashemi, A., Hazarkhani, H., Abdolmaleki, A. (2004) *J. Polym. Sci, Part A: Polymer Chemistry*, 42, 2106-2111.
- Bolker, H.I. (1965) *J. Polym. Sci., Part C: Polymer Symposia*, 11(1), 49-73.
- Hajas, J.; Woocker, A. (2002) *Macromolecular Symposia*, 187(1), 215-224. 28.
- Haque, P. Mustafa, A. I. Khan, M. A. (2007) *Carbohydrate Polymers*, 68, 109-115.
- Ferdous, S., Mustafa, A. I., Khan, M. A. (2003) *J. Macromol. Sci., A*, 40(8), 817-832.
- Shreve, R.N., Brink, J.A. *Chemical Process Industries*: McGraw-Hill, Inc., 413, 1977.
- Auton, M., Holthauzen, L.M.F., Bolen, D.W. (2007) *PNAS*, 104, 15317-15322.
- Viengkhou, V., Ng, L.T., Garnett, J.L. (1997) *Radiat. Phys. Chem.*, 49, 595-601.
- Rahman, M.M., Khan, M.A., Uddin, M.K., Ali, K. M.I., Mustafa, A.I. (2001) *J. Appl. Polym. Sci.*, 8, 1858-1867.
- Vieira, F.F., Mastro, N.L.D. (2002) *Radiat. Phys. Chem.*, 63, 331-332.
- Dworjanyan, P.A., Garnett, J.L., Khan, M.A., Maojun, X., Meng-Ping, Q., Nho, Y.C. (1993) *Radiat. Phys. Chem.*, 42, 31-40.